



ARMORMAN 4x4

1300 3075 43

Sales@armorman4x4.com.au
www.armorman4x4.com.au

BUSHMASTER- ARMOR BAR LDV-T90 (2022-ON)



**READ THE INSTALLATION INSTRUCTIONS CAREFULLY TO AVOID DAMAGING
THE VEHICLE OR THE COMPETITIVE BAR !!!**



(PLEASE CHECK THAT THE ACCESSORIES ARE COMPLETE)

COMPETTIVE BARS AND ACCESSORIES



1X BULL BAR

1X WINCH BRACKET

2X RECOVERY BRACKET/ RED

1X LOWER GUARD

2X BIPLANE GUARD

X3 UNDER BAR



LIGHTS AND OTHER ACCESSORIES

Note. ORIGINAL LIGHTS NEED TO BE USED FOR THIS MODEL OF LDV T90

PREPARE THE VEHICLE FOR INSTALLING THE BAR

1- Check the packing list

2. Remove and retain the number plate if fitted, to be reinstalled later. Remove the factory number plate holder.
Disconnect the negative battery terminal if applicable.



WARNING

Please check owner's manual for vehicle specific requirements, as some models may require battery back up.



3. Remove clips at front and rear of plenum cover.
Remove plenum cover and place aside.



4. Remove the four (4) bolts securing the upper section of the grille.
If vehicle is fitted with a front camera, disconnect this now (1).

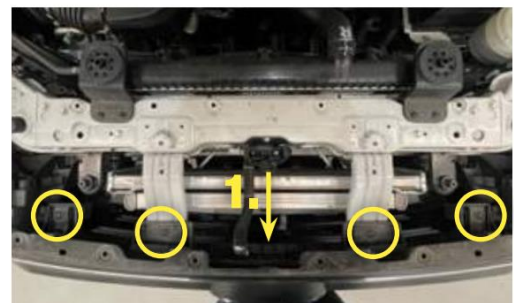



- 5.** Remove the three (3) clips and screw securing the guard liner to the factory bumper.
Repeat procedure on opposite side.



- 6.** Unbolt and remove all bolts securing the front and middle factory splash pans.
Remove pans.

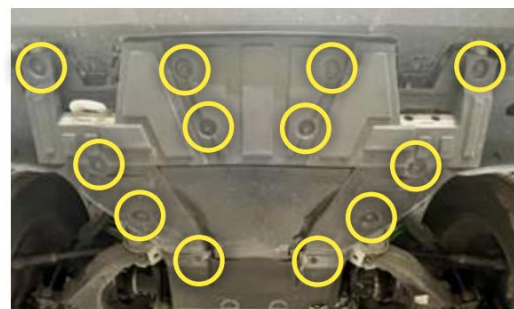

7. It is full bumper replacement bar, the full bumper need to come off-

- 8.** Unplug the bumper loom from behind the factory bumper, underneath the left-hand side headlight.



- 9.** Remove the bumper by carefully unclipping starting on the left corner, moving away from the headlight.
Gently place OE bumper to the side.





- 10.** Unbolt and remove the bolts **(1)** from the bumper reinforcement bar.

Remove the reinforcement bar and discard.

Unbolt and remove the bumper support bars **(2)** from the crossmember. Two (2) on each side and the one (1) in the centre, only if fitting a winch. This is replaced by the central support bracket supplied.

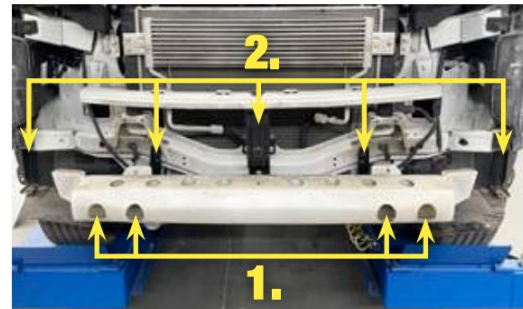

Installation of the Bull Bar

- 11.** Bring both the inner chassis bracket and recovery point together, surrounding the chassis rail. Loosely secure both parts to the chassis rail

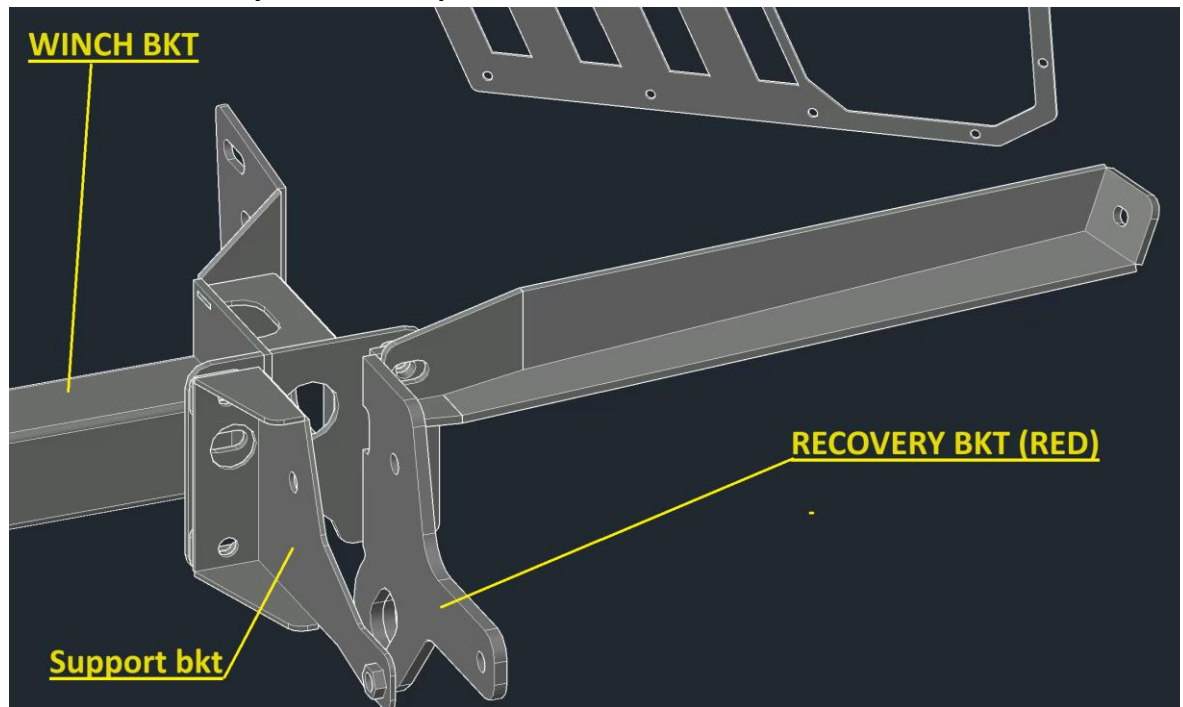



Lift cradle into place and align over bolt studs in fish plate. Secure with OE nuts removed earlier and M10 washer

